

Eclipse ThermJet Burners

for Preheated Combustion Air

Model TJPCA0040

Version 2

Parameter			Specifications		
			Natural Gas	Propane	Butane
Maximum Input BTU/hr (kW)			400,000 (117)	400,000 (117)	400,000 (117)
Minimum Input, On-Ratio BTU/hr (kW)			40,000 (11.7)	40,000 (11.7)	40,000 (11.7)
Gas Inlet Pressure Required "w.c. (mbar) Fuel Pressure at Gas Inlet <i>(Tap "B" - see page 3)</i>	Combustion Air Temp	Ambient	5.5 (13.7)	5.5 (13.7)	5.0 (12.4)
		300°F (150°C)	7.2 (17.9)	7.4 (18.4)	6.9 (17.2)
		700°F (370°C)	10.3 (25.6)	10.9 (27.1)	10.4 (25.8)
		1000°F (540°C)	12.7 (31.4)	13.5 (33.5)	13.0 (32.3)
Air Inlet Pressure Required "w.c. (mbar) 15% Excess Air at Maximum Input <i>(Tap "A" - see page 3)</i>	Combustion Air Temp	Ambient	3.4 (8.5)	3.4 (8.5)	3.4 (8.5)
		300°F (150°C)	4.9 (12.2)	4.9 (12.2)	4.9 (12.2)
		700°F (370°C)	7.4 (18.4)	7.4 (18.4)	7.4 (18.4)
		1000°F (540°C)	9.4 (23.4)	9.4 (23.4)	9.4 (23.4)
High Fire Flame Length Inches (mm) <i>(Measured from End of Combustor)</i>			<18.0 (457)	<19.0 (483)	<19.0 (483)
Flame Detection			UV scanner available for all combustors.		
Fuel <i>For any other mixed gas, contact Eclipse for orifice sizing.</i>			Natural gas, propane, or butane.		

- All information is based on laboratory testing in neutral (0.0" w.c.) pressure chamber. Different chamber size and conditions may affect the data.
- All information is based on standard combustor design. Changes in combustor will alter performance and pressures.
- All inputs based upon gross calorific values.
- Eclipse reserves the right to change the construction and/or configuration of our products at any time without being obliged to adjust earlier supplies accordingly.
- Plumbing of air and gas will affect accuracy of orifice readings. All information is based on generally acceptable air and gas piping practices.

Performance Graphs

Ignition & Operational Zones

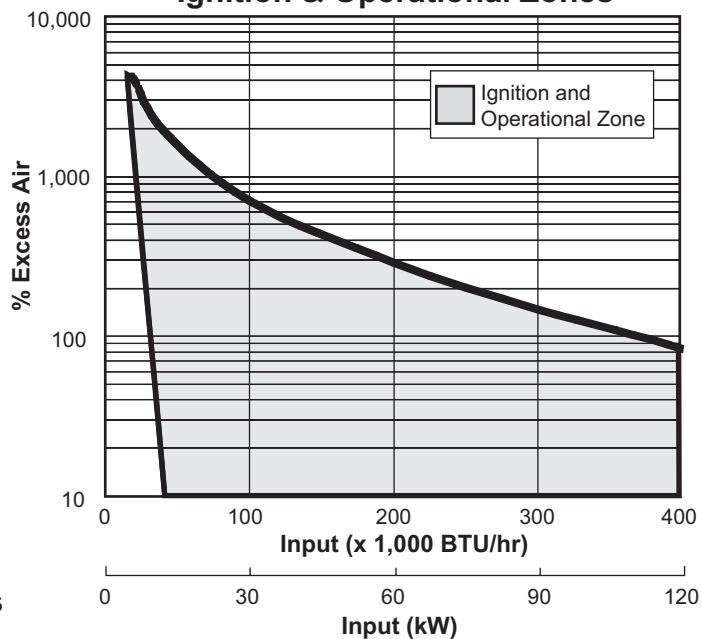

NO_x vs. Preheated Air Temperatures (Based on Maximum Firing Rate)

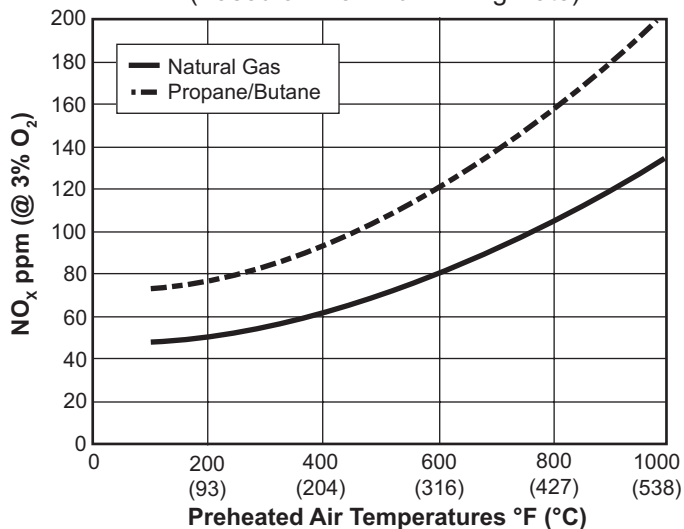

Emissions from the burner are influenced by:

- Fuel type
- Combustion air temperature
- Firing rate
- Chamber conditions
- Percent of excess air

For estimates of other emissions, contact Eclipse.

Gas Orifice ΔP vs. Input (Measured from Tap B to Tap D)

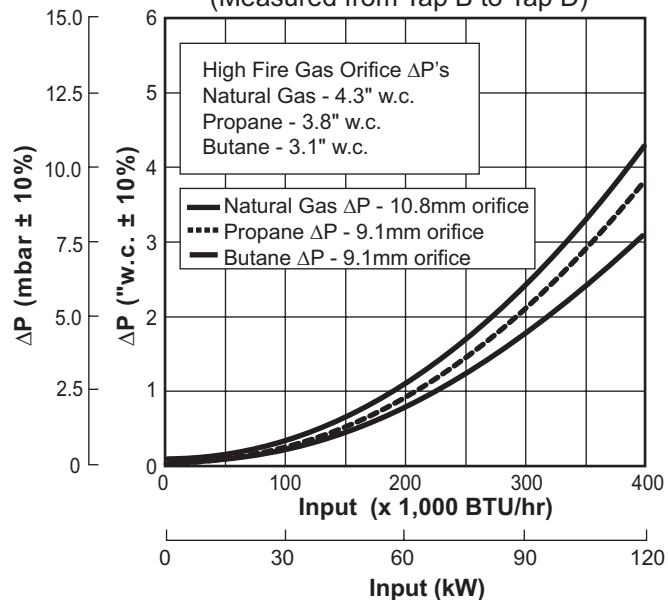

Dimensions in inches (mm)

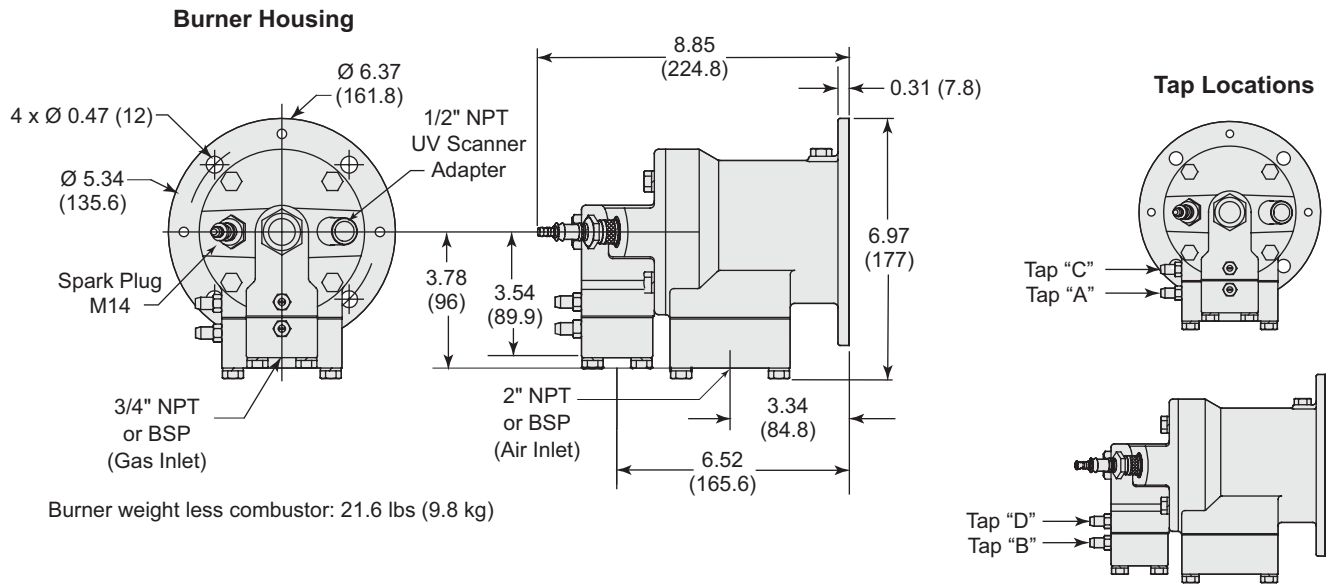

Combustor

Exhaust Outlet Diameter - Medium Velocity: Ø2.36 (60)

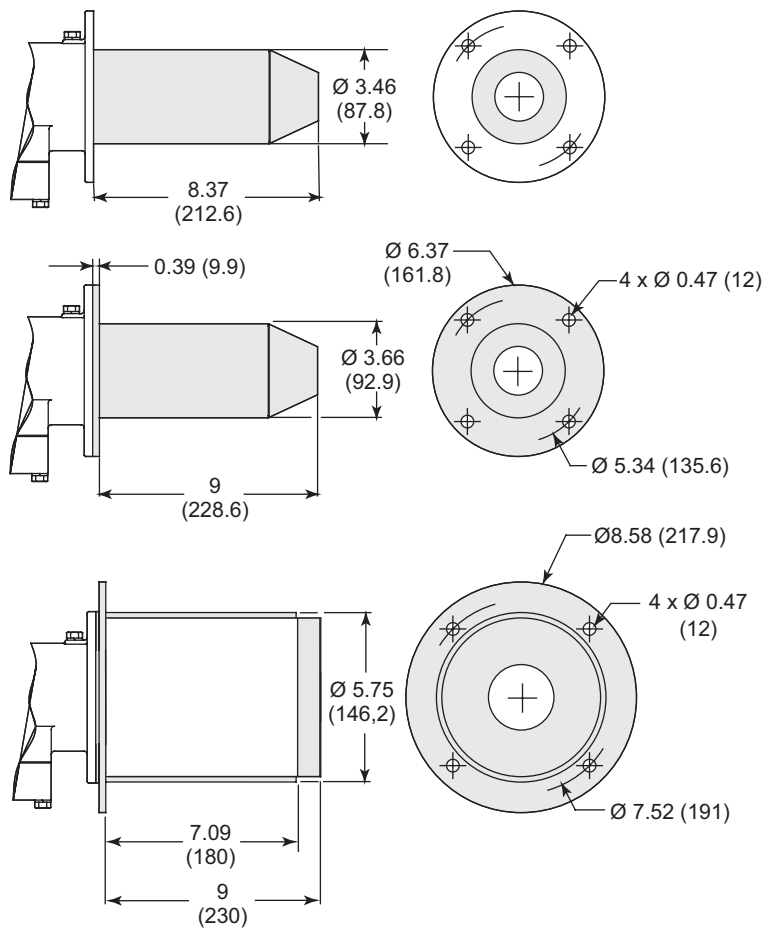

Alloy Tube (AISI 310)

Weight: 2.1 lbs (0.95 kg)

Maximum Chamber Temp: 1,750°F (950°C)
(Not suitable for preheated air over 700°F)

Silicon Carbide Tube

Weight: 3.6 lbs (1.63 kg)

Maximum Chamber Temp: 2,200°F (1200°C)

Refractory Block (w/330 SS wrapper)

Weight: 14 lbs (6.35 kg)

Maximum Chamber Temp: 2,800°F (1538°C)



Offered By:

Power Equipment Company
2011 Williamsburg Road
Richmond, Virginia 23231
Phone (804) 236-3800
Fax (804) 236-3882

www.peconet.com